

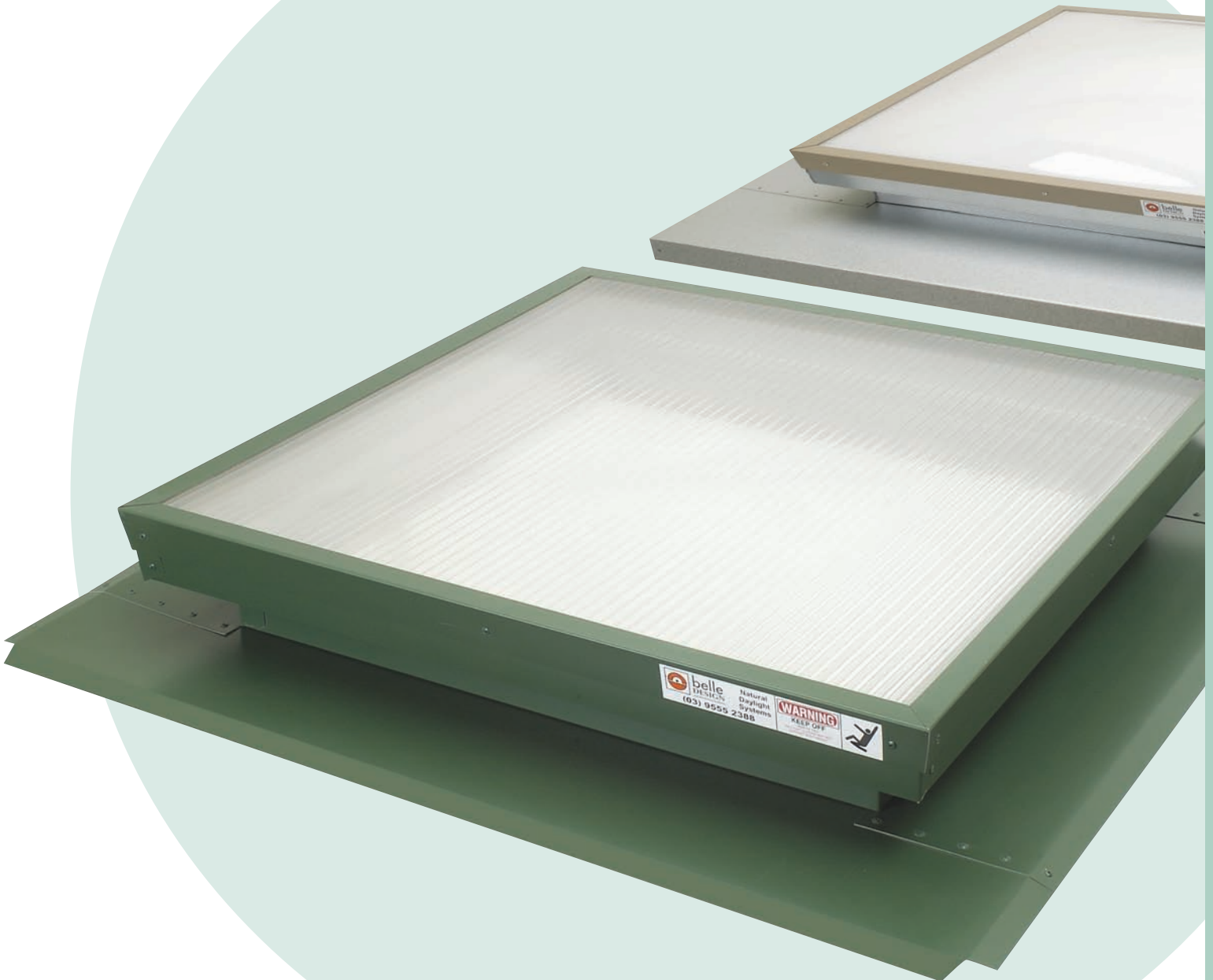

# ThermoLite™ and ThermoLite+™

*Energy efficient light control*



**belle**

Proudly Australian Made and Owned by **Belle Design & Manufacturing**



# ThermoLite™ & ThermoLite+™

## NATURAL DAYLIGHT SYSTEMS

### Belray ThermoLite™

#### Features:

- Belray ThermoLite™ & ThermoLite+™ energy saving skylights that offer quality, durability and high 90% light transmission all year round.
- The visually pleasing appearance of the ThermoLite™ range of low profile skylights come with excellent insulating characteristics and savings up to 50% in fuel costs over single glazing. Large standard size range from 500 square to 1200 x 1200 or larger sized modules on request, also available as a circular skylight P.O.A. Clear outer moulded insulating dome gives added heat reduction, as well as promoting self cleaning, gives required water run-off when used in deck roof applications.
- ThermoLite™ range has excellent fire resistant properties (refer fire indice chart) and is virtually unbreakable, impact strength is over 250 times greater than float glass and at least 10 times greater than acrylic.
- Excellent weather resistance, a special solar grade finish is applied which protects the ThermoLite™ top from discolouration and wear.
- Suitable for all roof types, Colourbond flashings available to co-ordinate with roof colour (standard Zincume or Galvanized).

### ThermoLite™ Standard Size Chart\* (Includes ThermoLite+™)

size (mm)	actual throat size (sq.m)	ventilation area (sq.m)
500 X 500	0.25	0.081
600 X 600	0.36	0.095
800 X 800	0.64	0.122
900 X 900	0.81	0.136
1000 X 1000	1	0.149
1200 X 1200	1.44	0.176
500 X 800	0.4	0.102
500 X 900	0.45	0.104
500 X 1000	0.5	0.112
600 X 800	0.48	0.108
600 X 1200	0.72	0.136
800 X 1200	0.96	0.149
900 X 1200	1.08	0.156

\* Other sizes available P.O.A.

### Efficiency Chart

#### Insulation Efficiency

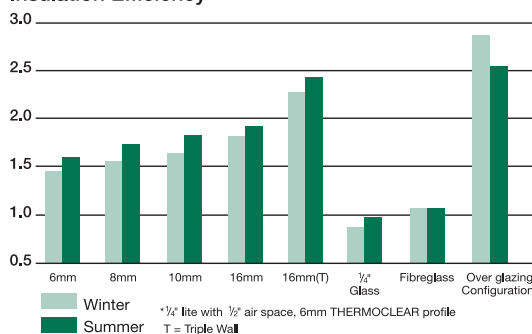

#### To Specify:

#### When ordering quote:

**Belray ThermoLite or ThermoLite+** depending insulation quality required. Vented or non vented, roof type, roof material, roof colour if required, size and if not square, measurement across roof x length up roof. Circular ThermoLites available on request.

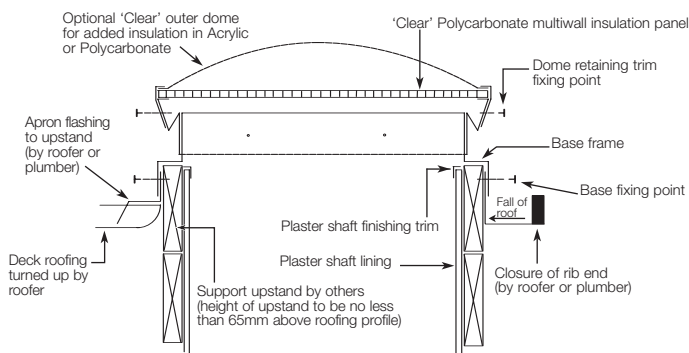

Belle Design Skylights are select tested to AS 4285-1995

#### Custom Moulded and Fabricated Plastics

- design and construct
- qualified, experienced tradesmen
- full installation or supply only
- commercial and domestic projects
- to architect's, builder's & roofer's specs
- custom made and standard sizes
- barrel vaults, canopies, Longlites
- double and single glazed
- glass skylights & overhead glazing
- circular skylights
- roof access hatches



## belle

### DESIGN AND MANUFACTURING

125 Chesterville Road  
Moorabbin VIC 3189

(03) 9555 2388  
(03) 9532 3470

info@belledesign.net  
www.belledesign.net

BELLE DESIGN - Specialising in natural daylight systems

