



OpalLite & ClearLite

Energy Efficient Light Control



adding daylight to life

Proudly Australian Made & Owned





OpalLite & ClearLite

Energy Efficient Light Control

Economical Daylight Systems

- OpalLite and ClearLite Skylights are ideally suited for domestic and commercial applications.
- The OpalLite skylight kit comprises of a skylight with roof flashing, highly reflective flexible shaft, white ceiling trim and opal or prismatic diffuser.
- The FlexiShaft used in the system is comprised of a highly reflective fibre reinforced triple laminated material designed for skylights. This material's ultra reflective inner surface delivers light entering the dome to the diffuser. The triple layer construction prevents any light leakage or U.V. breakdown.
- The U.V. stabilised acrylic is available in clear, opal or tinted finishes.
- OpalLite and ClearLite domes are also available in high impact acrylic and polycarbonate.
- OpalLite and ClearLite is suitable for all roof types.
- Available in Colorbond®, Zinalume® and galvanised finishes.
- Available with an exhaust fan option.

OpalLite & ClearLite Standard Size Chart*

size (mm)	actual throat size (sq.m)	ventilation area (sq.m)
400 X 400	0.16	0.059
500 X 500	0.25	0.081
550 X 550	0.3	0.088
600 X 600	0.36	0.095
750 X 750	0.56	0.112
900 X 900	0.81	0.136
1000 X 1000	1	0.149
1200 X 1200	1.44	0.176
400 X 600	0.24	0.08
500 X 800	0.4	0.102
500 X 1200	0.6	0.129
600 X 1200	0.72	0.136

* Other sizes available

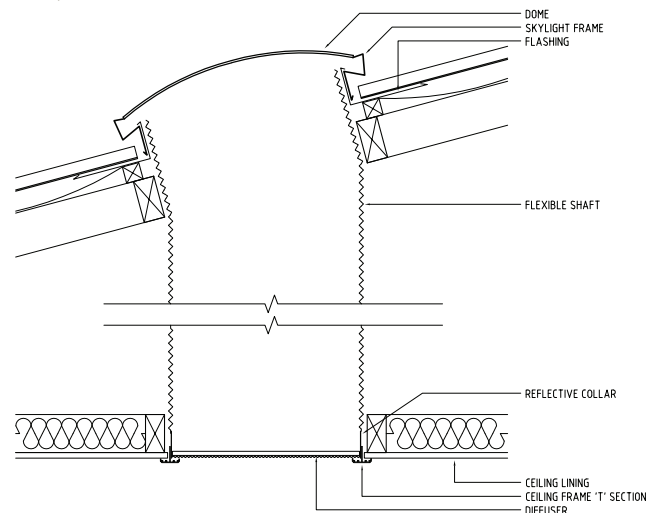

Tested to AS4285-2007 (up to 1500x1500mm)



125 Chesterville Road
 Moorabbin VIC 3189
 Tel (03) 9555 2388
 Fax (03) 9532 3470
 Email info@belleskylights.com.au
 Web www.belleskylights.com.au

